

MAKE	
MODEL	
YEAR	
BOLT PATTERN	
FENDER HEIGHT	
FACTORY WHEEL SIZE	
FACTORY TIRE SIZE	
A MOUNTING SURFACE TO FIRST OBSTRUCTION FRAME SIDE	
B MOUNTING SURFACE TO INSIDE FENDER	
C HUB DIAMETER	
D BRAKE DIAMETER: CENTER TO TOP OF CALIPER (x2)	
E PROTRUSION OF CALIPER PAST MOUNTING SURFACE	
F HUB LENGTH	

# FRONT WHEEL SECTION THROUGH FENDER WELL

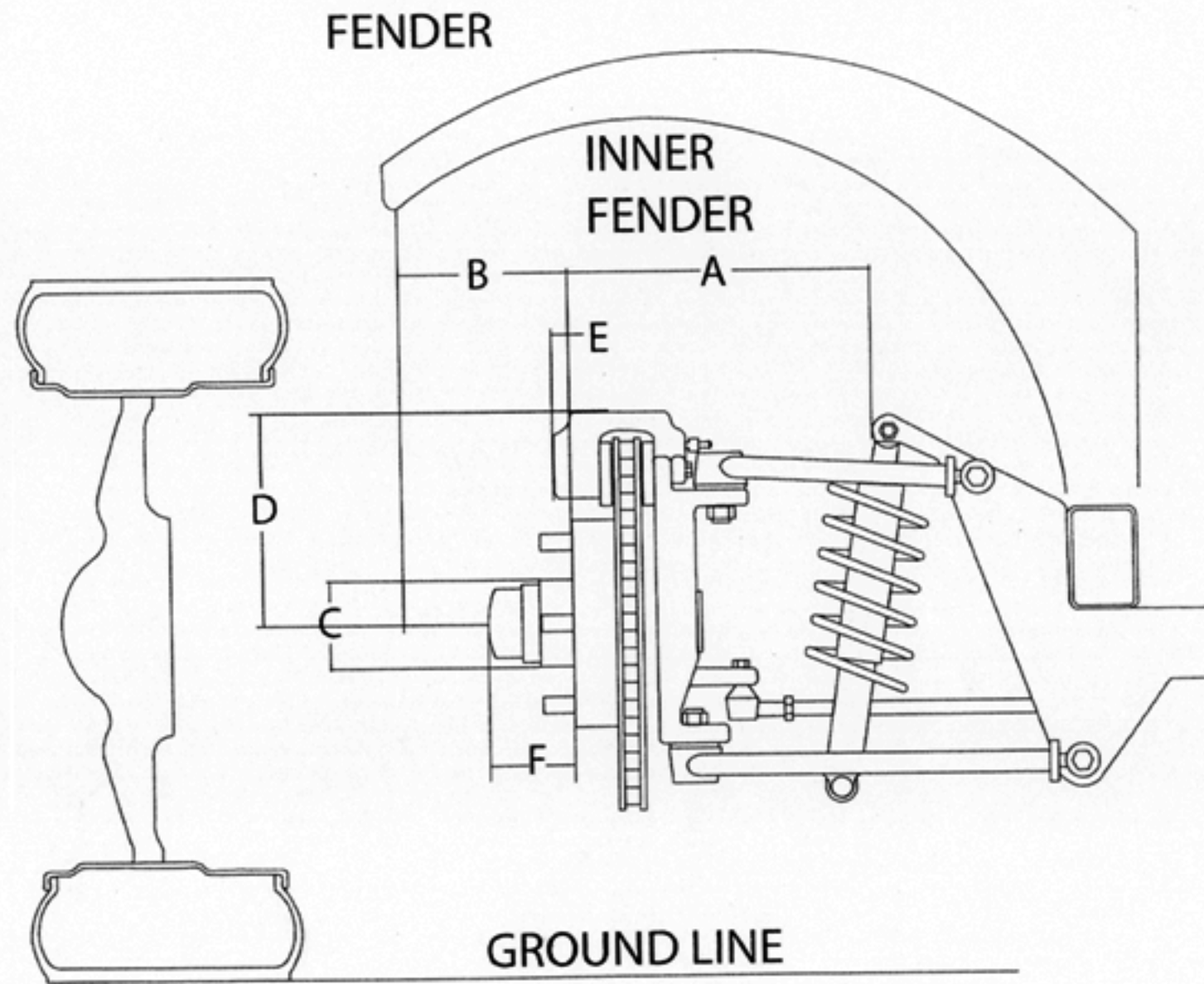

GROUND LINE

MAKE
MODEL
YEAR
BOLT PATTERN
FENDER HEIGHT
FACTORY WHEEL SIZE
FACTORY TIRE SIZE
A MOUNTING SURFACE TO FIRST OBSTRUCTION FRAME SIDE.
B MOUNTING SURFACE TO INSIDE FENDER.
C HUB DIAMETER
D BRAKE DIAMETER: CENTER TO TOP OF CALIPER (x2)
E PROTRUSION OF CALIPER PAST MOUNTING SURFACE (CALIPER DEPTH IF ANY)

